

21,80 Kg

Weight without
basket

120 L

Basket capacity

1.235 mm

Height

558 mm

Maximum diameter



FEATURES

Body and access lid manufactured in solid-coloured high-density polyethylene offering colour stability, total corrosion resistance, a smooth finish and the ability to absorb routine impacts without denting or cracking. High density polyethylene is stabilised against both UV radiation and water.

Manufactured using environmentally-friendly recyclable materials.

No heavy metals in the pigments.

They are designed with vertical fluting that reinforces the whole assembly providing originality and elegance. This fluting makes it difficult to stick posters and labels to the body of the bin.

Metal parts are electro-plated or hot-dipped galvanized to eliminate any corrosion points in the finished product.

Can be customised on the body, measuring 190 x 190 mm maximum.

STANDARDS

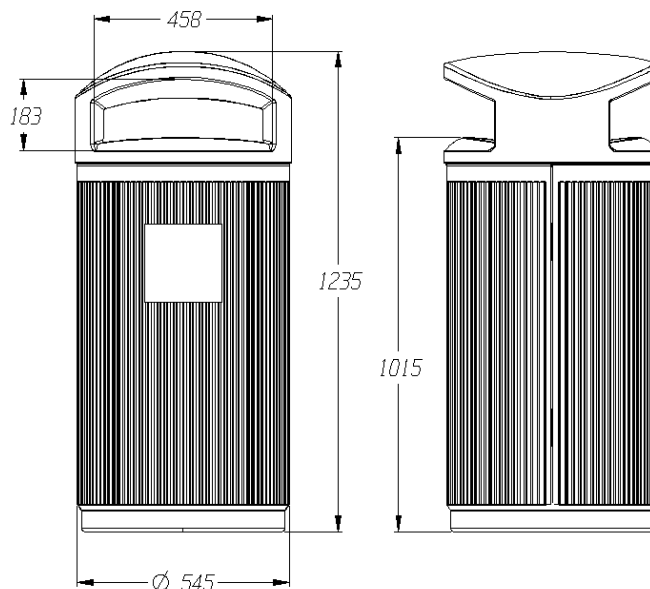

ATTRIBUTES



QUALITY



ERGONOMIC

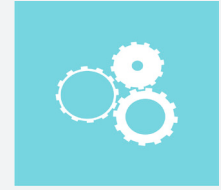

FUNCTIONALITY



EQUIPMENT

Filling area comprises two wide openings having 180° access, made up of an upper part that is joined to the body of the bin by two vertical locks giving the whole structure a high degree of mechanical strength.

A locking system with a standard triangular key is provided to prevent unauthorised access.

Integral cigarette stubber in the body; ashtray can be supplied on request.

120 litre basket fitted with an integral handle to make emptying easier.

There is the option of replacing the basket with a refuse sack. The system can also be used to segregate two separate materials if a two-compartment basket is fitted.

Vandal-resistant support frame is integrated into the body and fixed to the pavement simply and securely by means of four 12 mm universal expansion bolts.

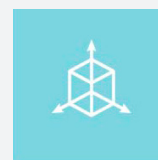

Design

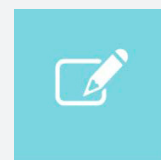

Customised

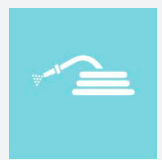

Easy to clean



Easier maintenance



Easier assembled

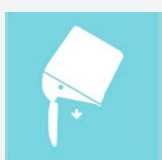

Easier emptying