

208_{Kg}
Weight

3.200_L
Capacity

800_{Kg}
Load

1.050_{mm}
Height of opening

1720 x 1500 x 1800
mm
Maximum Dimen-
sions

250 ó 250 mm
Diameter of openings



FEATURES

3,200-litre container for glass collection.

Especially designed for glass collection by crane lifting system.

Manufactured from solid-coloured high density linear polyethylene and stabilised against the combined effects of UV radiation and water, it is highly resistant to atmospheric conditions.

Smooth surfaces.

Colour stability.

Total corrosion resistance.

With an exclusively-designed Contenur outline brace, making the assembly robust and hard-wearing.

Manufactured according to European standard EN 13071-1 General Requirements and EN 13071-2 Specific Requirements.

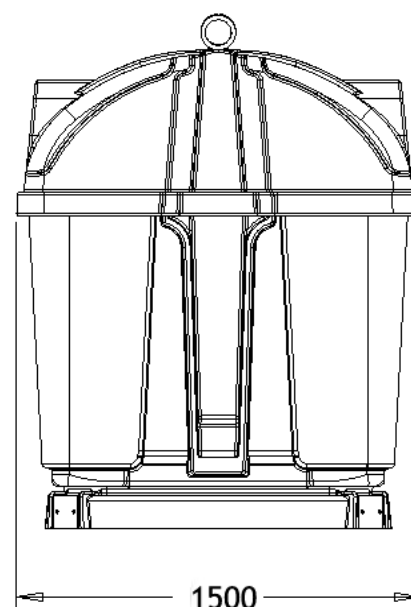
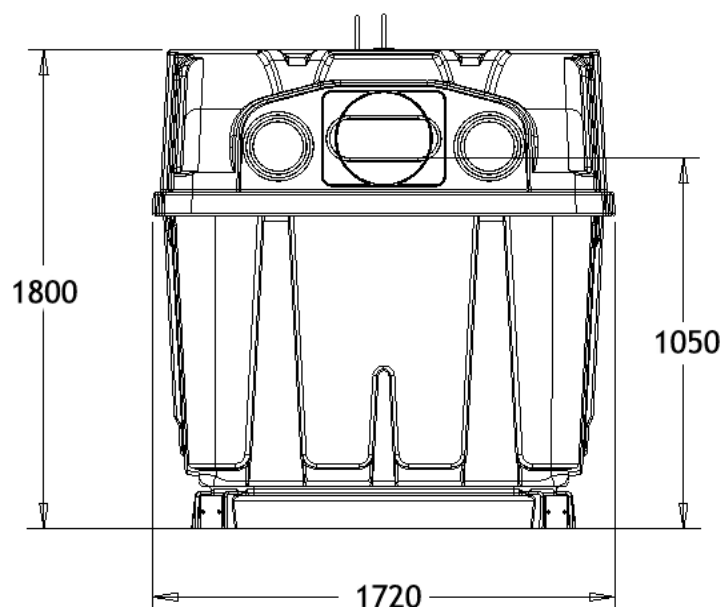

ATTRIBUTES

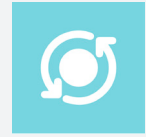

AVAILABLE IN A WIDE RANGE
OF COLOURS



EQUIPMENT

Double hook or Kinshofer crane lifting system.

Circular 200/250-mm openings located at a maximum height of 1.005 mm. from the ground to facilitate user access.

Discharge doors manufactured from rotationally-moulded high density polyethylene.

The lifting / emptying system is corrosion resistant steel and is located on the upper part of the container.

They can be supplied on order with silk-screening incorporated into the body, customised colour, reflecting bands.

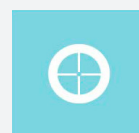

Circular openings



Customised



Glass opening



Kinshofer

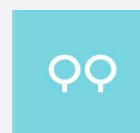

Double hook

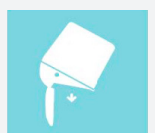

Easy emptying