

“MORMEDI” STEEL CONTAINER



The large capacity, crane-lift “Mormedi” Steel Container is a remarkably hard-wearing, solidly-made container with smooth, rounded lines. Easily suited to any urban environment, it provides effective solutions for the selective waste collection of paper and cardboard, but can also be used to collect glass and plastics with the addition of special apertures.

The container is manufactured using hot dip galvanized steel, which provides a low-maintenance product with a high degree of resistance to atmospheric agents.

Contenur designs and manufactures its containers using ISO 9001-standard procedures and the environmental management system is ISO 14001 certified for quality assurance.

The Contenur Group guarantees the quality of all its products and installations, and on client request can also offer a complete product maintenance programme.

“MORMEDI” STEEL CONTAINER

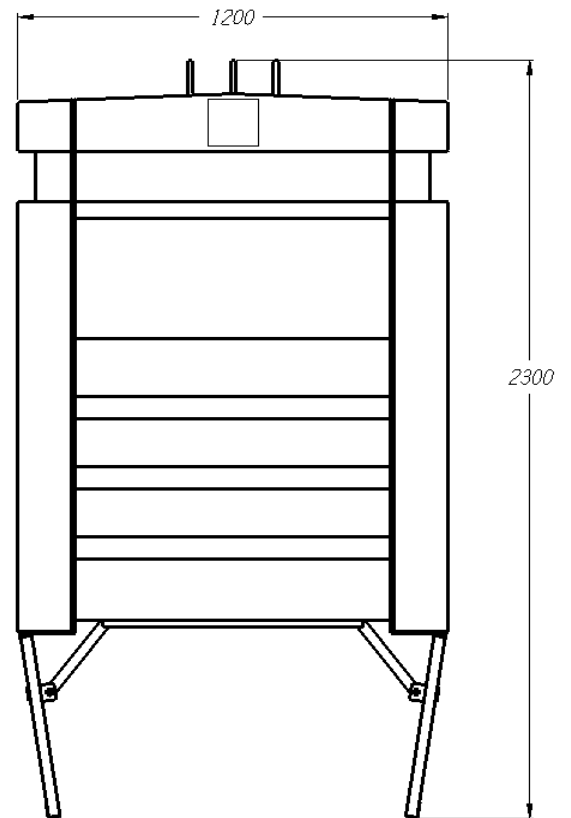
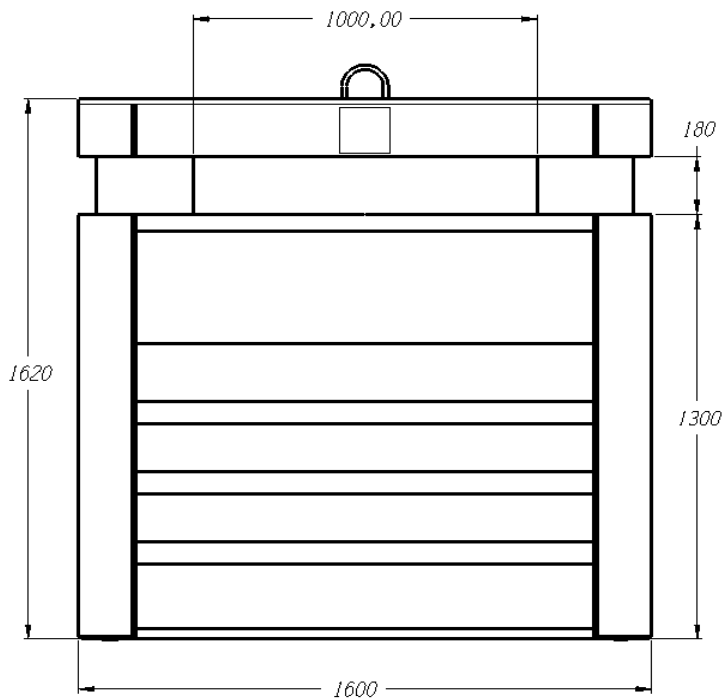

TECHNICAL SPECIFICATIONS

CAPACITY 3,000 l
MAXIMUM LOAD 1,600 kg
DIMENSIONS 1,6 x 1,2 x 1,62 m

HEIGHT AT APERTURES 1,300 mm
WEIGHT 268 KG
STANDARD APERTURES
Two 1,000 x 180 mm units

GENERAL SPECIFICATIONS

- Metallic container for paper and cardboard collection with a capacity of 3 cu mtr.
- Can be adapted to collect glass and plastics using addon apertures.
- Galvanised plate steel body with single piece, colddrawn corner columns.
- The side panels are welded to the columns, and are folded to provide extra strength.
- The aperture is kept closed by means of a pivoting door to prevent water ingress and air ingress in the event of fire.
- Cowl top designed with a slight camber to prevent water accumulation.
- Double hook lifting system.
- Unloading system with doors that pivot sideways to allow the container to be emptied completely.
- All metal parts, welds, drill holes, etc. are hot dip galvanised and then cold galvanised to avoid rust points and to keep the product in good condition.
- Paintwork is standard antirust grey RAL 7032 for the body and blue RAL 5002 for the apertures.
- Options available on request:
 - 250 mm or 300 mm circular apertures.
 - wide-mouthed apertures with a locking mechanism.
 - special anti-graffiti treatment.
 - customised colour and silk-screen graphics.
 - reflective strips.