

8,5 Kg
Weight with support

50L
Capacity

858 mm
Height

375 mm
Maximum width



FEATURES

The body and lid are injection moulded in solid coloured high-density polyethylene.

Manufactured using environmentally-friendly recyclable materials.

No heavy metals in the pigments.

They are designed with vertical fluting that reinforces the whole assembly providing originality and elegance. This fluting makes it difficult to stick posters and labels to the body of the bin..

Customisation: Body – printing or badge – maximum size: 190 x 190 mm. Lid – photo transfer print – 370 x 150 mm or 78 mm diameter. Lid option – 78 mm diameter embossing insert.

STANDARDS

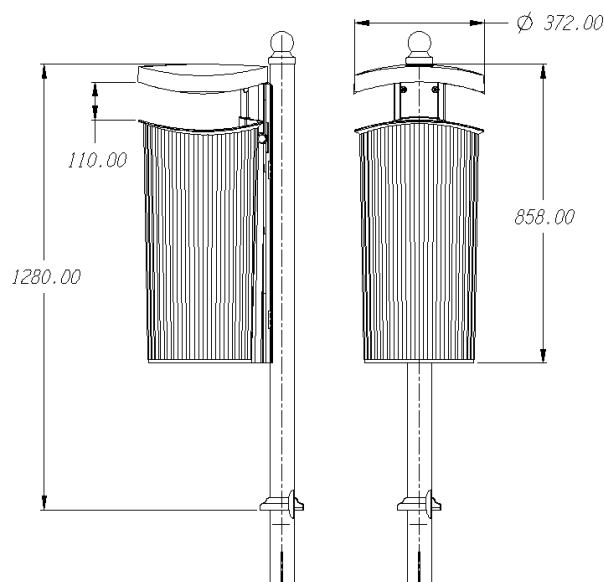

ATTRIBUTES



QUALITY



ERGONOMIC



DESIGN



EQUIPMENT

The filling area is covered by a lid attached to the fixing bracket, providing almost 360 degrees of access for depositing litter.

The 50 litre high-density polyethylene basket is fitted with a locking system, employing a standard triangular key, preventing access other than by collection and maintenance staff.

The body incorporates a cigarette stubber; an ashtray can be supplied on request.

The vandal-resistant fixing post is made from I.H.A F- 112 steel tube and electro-plated to prevent rusting.

The mounting system, produced in engineered plastic, provides a robust frame that stays fixed inside the bin and facilitates easy installation to lampposts, posts and fences.

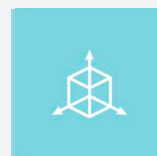

Design



Customised



Easy to clean

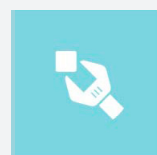

Easier maintenance

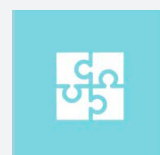

Easier assembled

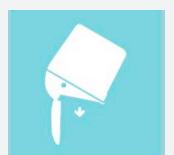

Easier emptying